



rp pn pn n r

n qn qt on

n r c r n



> r p n

n nD :o A
I bYSD

F



W D aV
UHDH D F



bHH F

c



n n

F



> n

TH

F



' " cxgc° g i vy dcvv cv h' S lhxxc

ii z

' : ; : @
lhxxc



I G1:q	aA	VH	QSV	HbHH U	I SGbS
TG1:q	I HA	VH	QSV	HbHH Ta	I SGbS
I S1:q	I VA	TH	GTV	I I WH S	I VGSH
TG1:q	SHA	TH	GTV	I I WH TU	aGHU
I 1:q	SVA	TH	GTV	I I WH HH	aGW
I 1 G1:q	TSA	SV	GVSV	I I WH I U	UGS
I 1 S1:q	UHA	SV	GVSV	I I WH I S	UGS
S1:q	VHA	SV	GVSV	I I WSHH	SGW
S1 S1:q	VWA	I a	SW	I I WSI S	I G
T1:q	aHA	I U	SH	I I WH HH	I Q
U1:q	I HA	I S	GYU	I I WH HH	I G



i A A @
v 6 DCAD; E ; F 7 "
d ; @
w S, DB e: CMB e @
" SI' y DDP 6 glx hx l' y DDP d' hx l' y DDP 7 @
c xz" DCAD: E F @



' " cxgc° g i vy dcvv cv h' S lhxxc

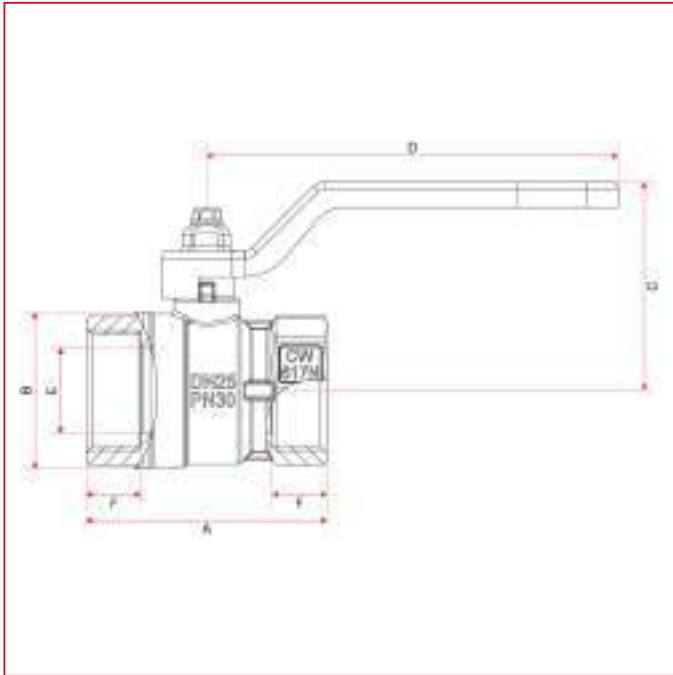

	i 3	rg 3	i 3	rg 3	i 3	i 3i 3	i 3i 3	o 3	o 3i 3	r 3	s 3
gx	P	CB	CM	DB	DM	ED	FB	MB	NM	PB	CBB
c	FF:F	FF:F	FP	ME	NN	ON	PP	CBE	ODP:M	CFM	COM
d	DE:M	DF	DR	EN	FE	ME	NE	CR	RO	COO:M	CFR:M
e	EOE	EOE	FB	MF	MD	OE	OP	RF	CCB	ODO	CFD
g	PB	PB	PB	CCE	CCE	CEP	CEP	CMP	CRO	DMB	DMB
h	CB	CB	CF	OP:M	DE:M	EB	EO	FO	MP	CB	FB
i	CB	CB	CD	CD	CM	ON	OP	CR	DF	DF	DO
o A D	MB	MB	EB	EB	EB	DM	DM	DM	CP	CF	CD
vd' ;	ODM	ODM	FEM	FEM	FEM	END:M	END:M	END:M	DNC	DBE	CCF



' " cxgc° g i v y dcvv cv h' S lhxxc

i g3 o3

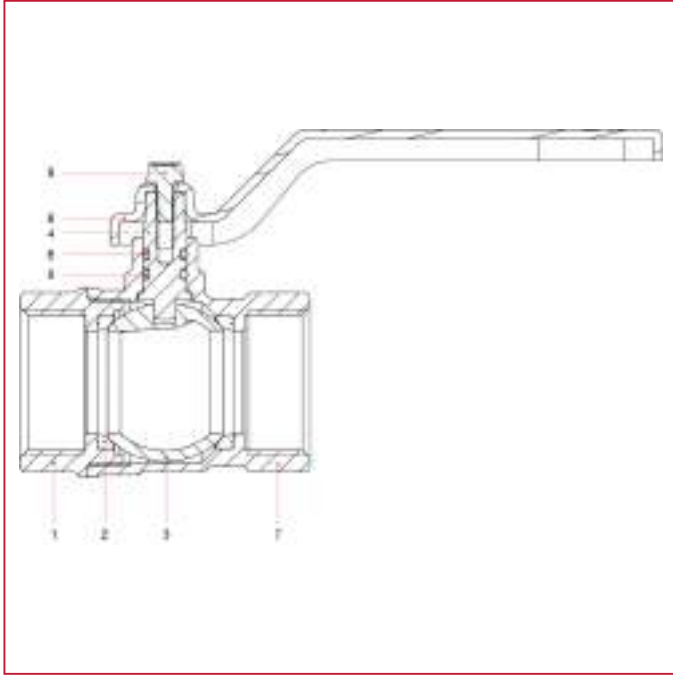

zy' @gh' e° lz" lyx	x@ wc" h° lcv
C i	C x ; e N00x
D '	D z@@@@
E d	C e ; e N00x
F '	C d e NCFx
M y;	C xd°
N y;	C
O d	C x ; e N00x
P v	C zBF
R '	C ; eFe



' " cxgc° g i v y dcvv cv h' S lhxxc

o3i g s3

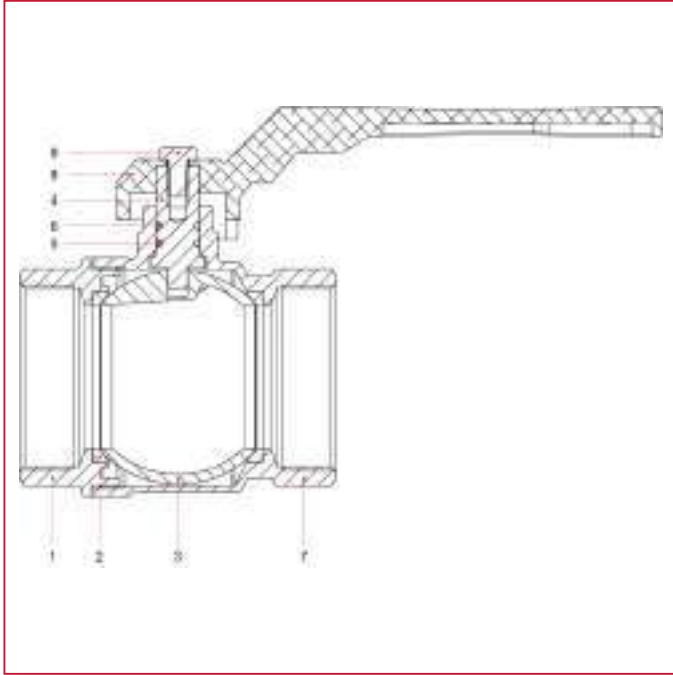

zy' @gh' e° lz" lyx	x@ wc" h° lcv
C i	C x ; e N00x
D '	D z@@@@
E d	C e ; e N00x
F '	C d e NCFx
M y;	C xd°
N y;	C
O d	C x ; e N00x
P v	C
R '	C ; edFii @EF7



' " cxgc° g i vy dcvv cv h' S lhxxc

" ' @@@ ; : z"ih : : @ 7.

" 6 : : @

| ; : @

i : T S

; ; ; ; T @

; ; ; ; @ 7 @ @

; ; ; ; @ @

gl' c' ' hwdv ; ; ; ; S T

" ; ; ; ; T T

; ; ; ; T

wclx" hxcxeh ; ; ; ; T

;

wcx ice" ° h° @

l" cz ' @@@

° CRDC; DMBNM

v @' 7.1

z S9ER BEB PRDOBCC

i S9ER BEB PRDCRRB

S b @

S @ @



' " cxgc° g ivy dcvv cv h' S lhxxc

G H

	CA/	EA/	CA/	EA/	C/	C/CA/	C/CA/	D/	D/CA/	E/	F/
o	E:EE	F:RD	CF:NM	DE:FN	EP:NO	MN:BO	PN:NB	CN:B:M	OPE:C	DPB:N	FNC

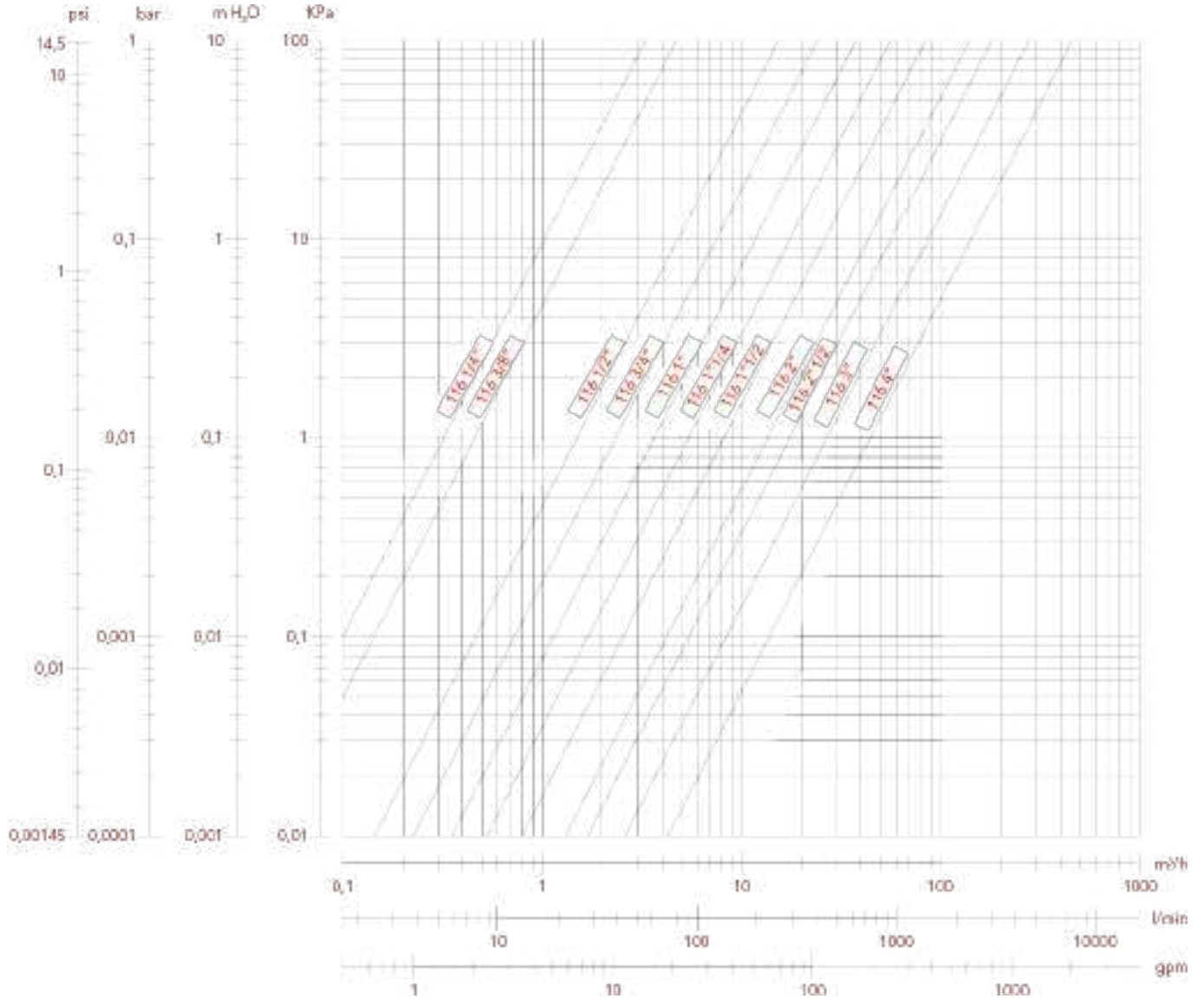



' "cxgc°g i vy dcvv cv h' S lhxxc

ii

' : ; : @
lhxxc



I G1:q	aA	VH	G'SV	Hbl HH U	I SGbS
TG1:q	I HA	VH	G'SV	Hbl HHTa	I SGbS
I S1:q	I VA	TH	GTV	I I YHH S	I VGSH
TG1:q	SHA	TH	GTV	I I YHHTU	aGVU
I 1:q	SVA	TH	GTV	I I YH HH	aGVU
I 1l G1:q	TSA	SV	GVSV	I I YH I U	UGTS
I 1l S1:q	UHA	SV	GVSV	I I YH I S	UGSU
S1:q	VHA	SV	GVSV	I I YSHH	SGS



i A A @
v 6 DCAD; E ; F 7 "
d ; @
w S,DB e: CMB e @
" Sl' y DDP6 glx hx l' y DDP d' hx l' y DDP7@



' " cxgc° g i v y dcvv cv h' S lhxxc

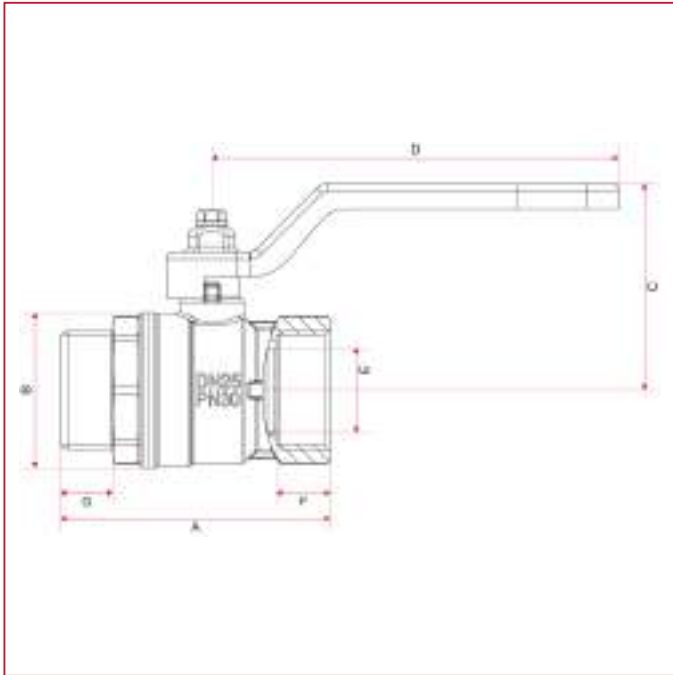

	i 3	r g 3	i 3	r 3	i 3	i 3 i 3	i 3 i 3	o 3
g x	P	OB	OM	DB	DM	ED	FB	MB
c	ME:R	ME:R	MP	ND:M	OM	PO:M	OBB:M	CCMM
d	DE:M	DF	DR	EN	FE	ME	NE	OR
e	EQE	EQE	FB	MF	MO	OE	OP	RF
g	PB	PB	PB	OCE	OCE	OEP	OEP	OMP
h	P	OB	CF	OP:M	DE:M	EB	EO	FO
i	OB	OB	OD	OD	OM	ON	OP	OR
j	OB:M	OB:M	OC:M	OD:M	OF:M	OO	OR	DC
o A D	MB	MB	EB	EB	EB	DM	DM	DM
vd' ;	ODM	ODM	FEM	FEM	FEM	END:M	END:M	END:M



' " cxgc° g i v y dcvv cv h' S lhxxc

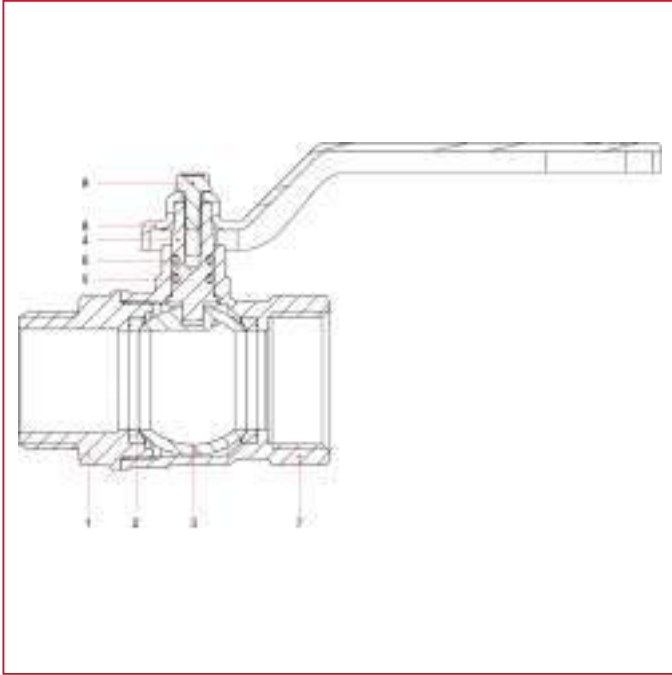

zy' @gh' e° lz" lyx	x@ wc" h° lcv
C w	C x ; e N00x
D '	D z@@@@
E d	C e ; e N00x
F '	C d e NCFx
M y;	C xd°
N y;	C
O d	C x ; e N00x
P v	C zBF
R '	C ; eFe



' "cxgc°g ivy dcvv cv h' S lhxxc

" ' @@@ ; : z"ih : : @ 7.

" 6 : : 7

@

| ; :

i : S @

; T

; @ "ih 7 T @

; : 6 : @ @

@ @

gl' c' ' hwdv

" S T

; S

; T

; T

; T

wclx" hxcxeh

: @

wcx ice" °h°

l" cz ' @@@

° CRDC; DMBNM

v @' 7.1

z S9ER BEB PRDOBCC

i S9ER BEB PRDCRRB

S b @

S @ @



' " cxgc° g i v y dcvv cv h' S lhxxc

G H

	CA/	EA/	CA/	EA/	C/	C/CA/	C/CA/	D/
o	E:EE	F:RD	CF:NM	DE:FN	EP:NO	M:BO	PN:NB	CN:M

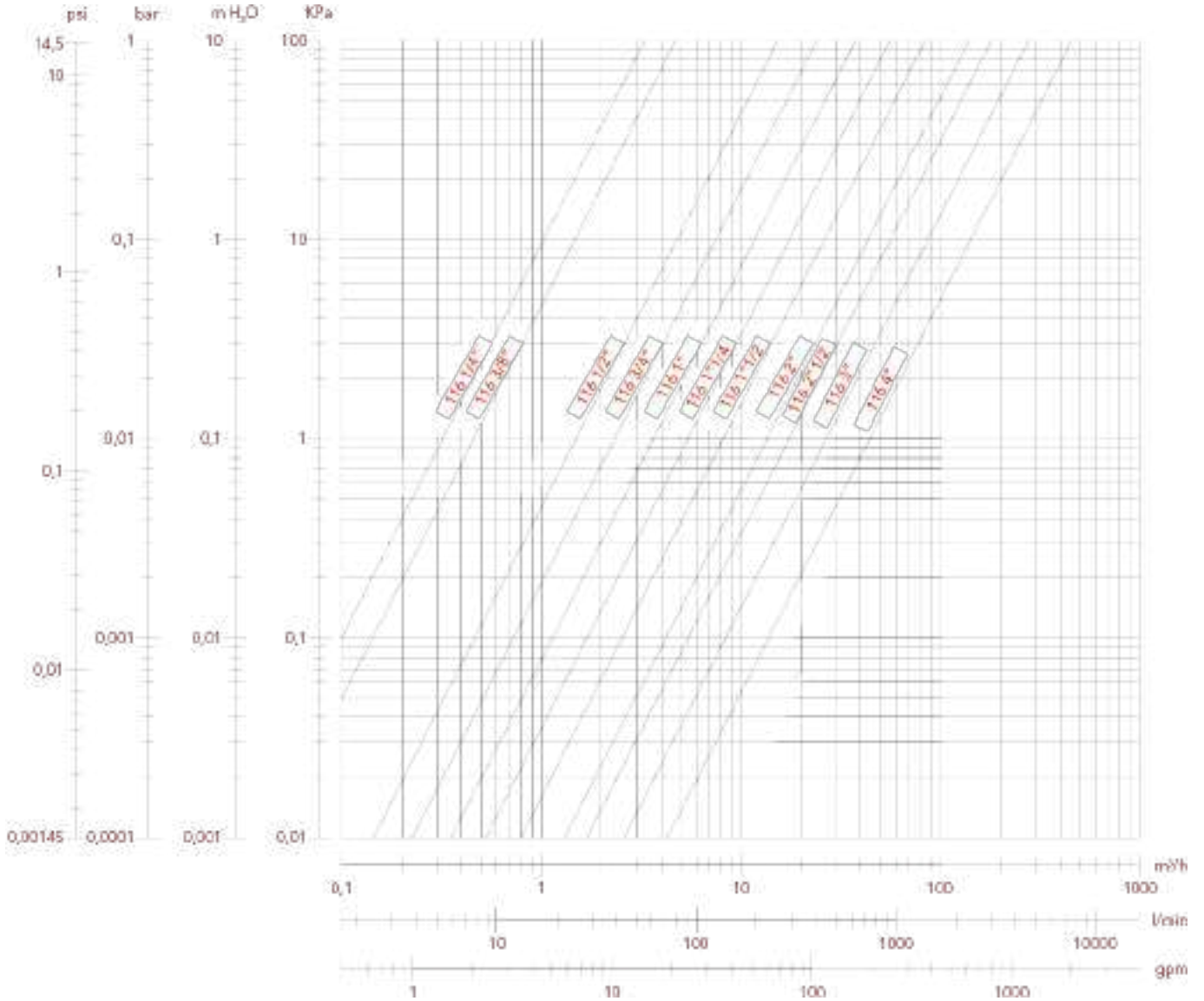



' " cxgc° g i vy dcvv cv h' S lhxxc

ii

:

' : ; : @
lhxxc



I G1:q aA	VH	ØSV	HbSHH U	I VGSUH
TG1:q I HA	VH	ØSV	HbSHHTa	I VGSUH
I S1:q I VA	TH	ØTV	I I aHH S	I VGbV
TG1:q SHA	TH	ØTV	I I aHHTU	a@a
I 1:q SVA	TH	ØTV	I I aH HH	a@H



i A A @
v 6 DCAD; E ; F 7 "
d ; @
w S,DB e: CMB e @
" Sl' y DDP6 glx hx l' y DDP d' hx l' y DDP7@



' " cxgc° g i v y dcvv cv h' S lhxxc

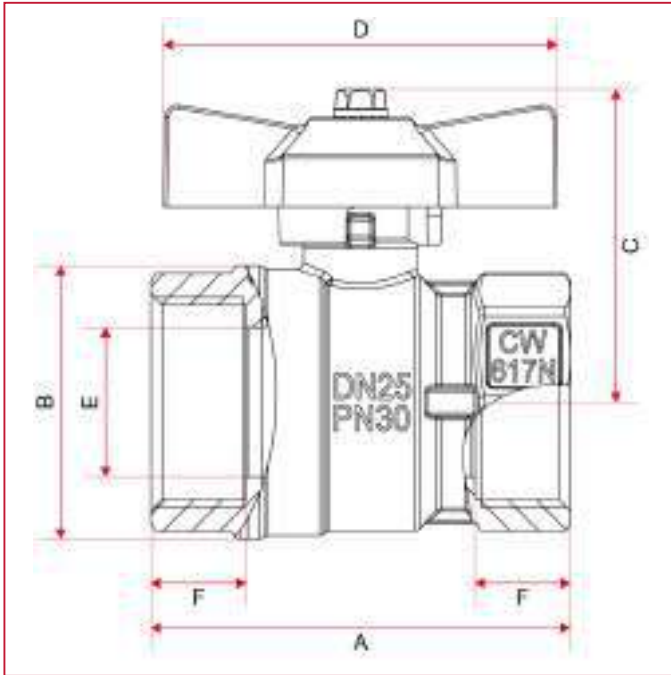

	i ϕ3	rg 3	i ϕ3	rg3	i 3
gx	P	CB	CM	DB	DM
c	FF:F	FF:F	FP	ME	NN
d	DE:M	DF	DR	EN	FE
e	EQE	EQE	FB	FN	FR
g	FO	FO	FO	MF	ND
h	CB	CB	CF	CP:M	DE:M
i	CB	CB	CD	CD	CM
o A D	MB	MB	EB	EB	EB
vd' ;	ODM	ODM	FEM	FEM	FEM



' " cxgc° g i v y dcvv cv h' S lhxxc

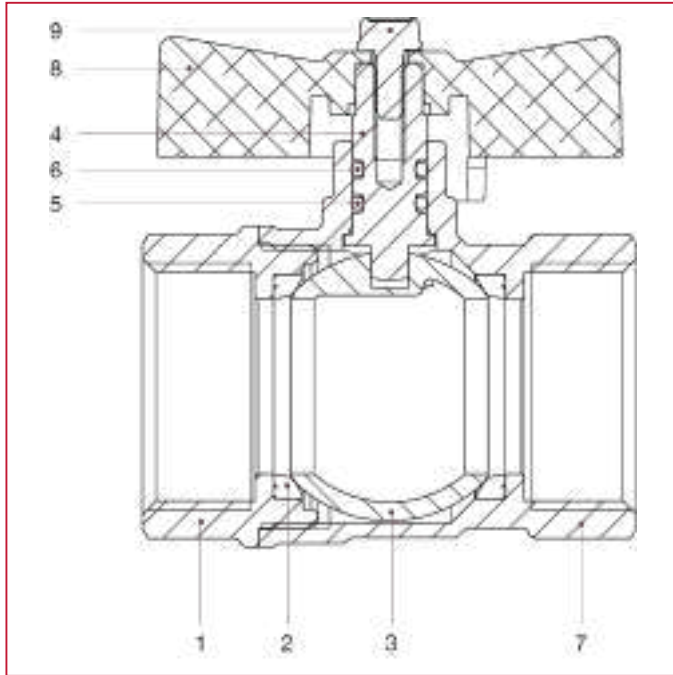

zy' @gh' e° lz" lyx	x@ wc" h° lcv
C i	C x ; e N00x
D '	D z@@@
E d	C e ; e N00x
F '	C d e NCFx
M y;	C xd°
N y;	C
O d	C x ; e N00x
P "	C
R '	C ; eFe



' "cxgc°g i vy dcvv cv h' S lhxxc

```

"      '@@@      ;      :
"      :      z"ih      :      :      @ 7.
      6      7
      @
|
;      :
i      :      S      @
;      T
;      @      7      T      @
;      :      :      @
;      ;      6      :      @
gl' c' ' hwdv      @      @
"      S      T
;      S      T
;      T
;      T
;      T
;      T
wclx" hxcxeh      :
      @
wcx ice" °h°
l" cz ' @@@
      ° CRDC; DMBNM
v      @' 7.1
z      S9ER BEB PRDOBCC
i      S9ER BEB PRDORRB
      S b @
      S @ @

```



' " cxgc° g ivy dcvv cv h' S lhxxc

G H

	CA/	EA/	CA/	EA/	C/
o	E:EE	F:RD	CF:NM	DE:FN	EP:NO

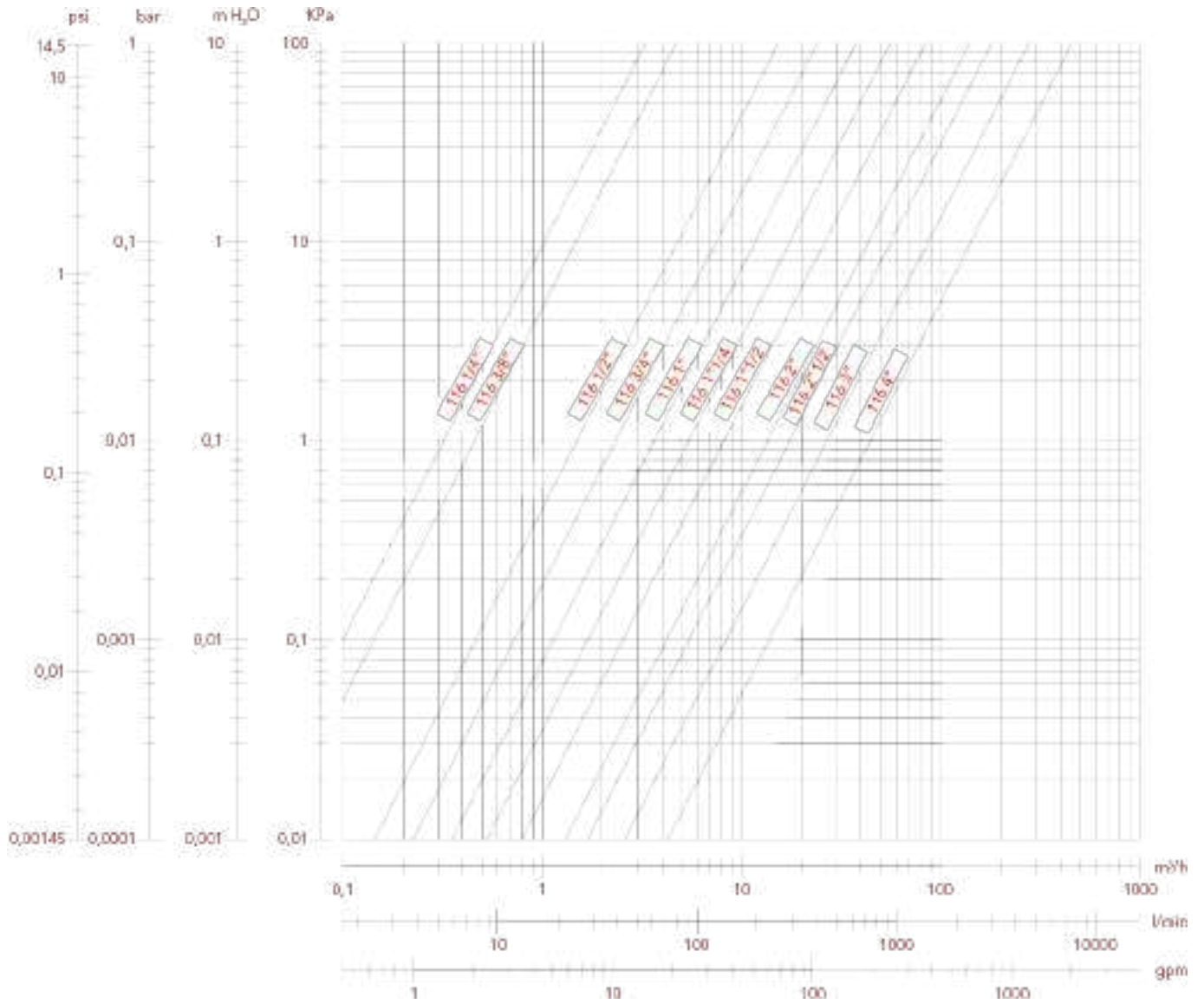



' " cxgc° g i vy dcvv cv h' S lhxxc

ii

:

' : ; : @
lhxxc



I G1:q aA	VH	ØSV	HbTHH U	I VGW
TG1:q I HA	VH	ØSV	HbTHHTa	I VGW
I S1:q I VA	TH	ØTV	I I bHH S	I VGSH
TG1:q SHA	TH	ØTV	I I bHHTU	a@a
I 1:q SVA	TH	ØTV	I I bH HH	a@W



i A A @
v 6 DCAD; E ; F 7 "
d ; @
w S,DB e: CMB e @
" Sl' y DDP6 glx hx l' y DDP d' hx l' y DDP7@



' " cxgc° g i v y dcvv cv h' S lhxxc

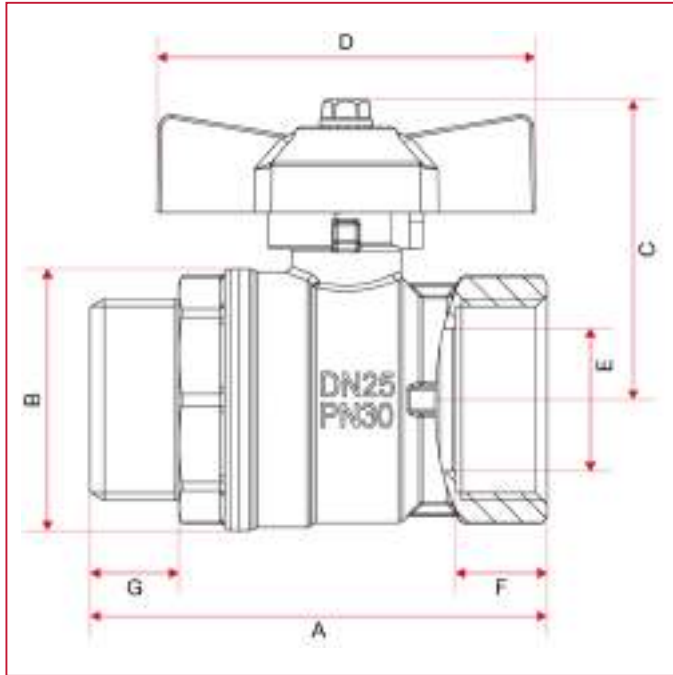

	i ϕ3	rg 3	i ϕ3	r ϕ3	i 3
gx	P	CB	CM	DB	DM
c	ME:R	ME:R	MP	ND:M	CM
d	DE:M	DF	DR	EN	FE
e	EQE	EQE	FB	FN	FR
g	FO	FO	FO	MF	ND
h	P	CB	CF	CP:M	DE:M
i	CB	CB	CD	CD	CM
j	CB:M	CB:M	CC:M	CD:M	CF:M
o A D	MB	MB	EB	EB	EB
vd' ;	ODM	ODM	FEM	FEM	FEM



' " cxgc° g i v y dcvv cv h' S lhxxc

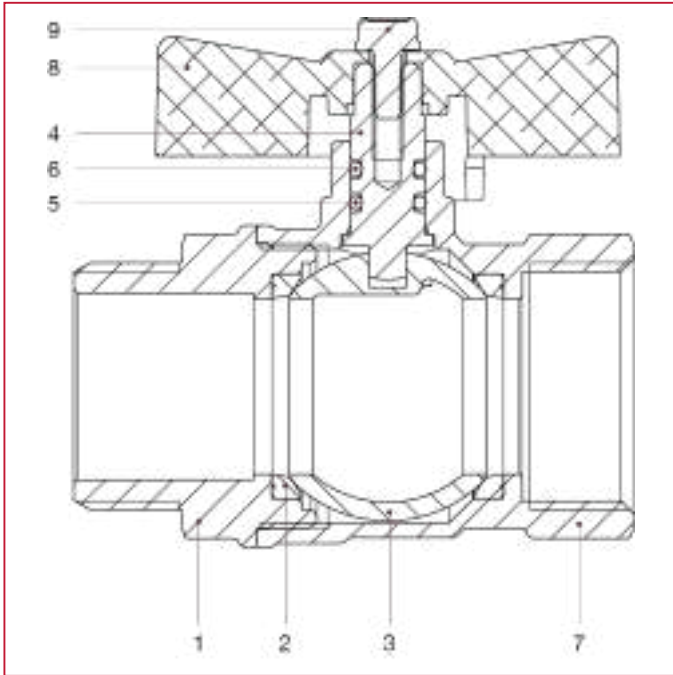

zy' @gh' e° lz" lyx	x@ wc" h° lcv
C w	C x ; e N00x
D '	D z@@@@
E d	C e ; e N00x
F '	C d e NCFx
M y;	C xd°
N y;	C
O d	C x ; e N00x
P "	C
R '	C ; eFe



' " cxgc° g i vy dcvv cv h' S lhxxc

" ' @@@ ; : z"ih : : @ 7.

" 6 : : @

| ; : @

i : T S

; ; ; ; T @

; ; ; ; @ 7 @ @

; ; ; ; @ @

gl' c' ' hwdv ; ; ; ; S T

" ; ; ; ; T T

; ; ; ; T

wclx" hxcxeh ; ; ; ; T

;

wcx ice" ° h° @

l" cz ' @@@

° CRDC; DMBNM

v @' 7.1

z S9ER BEB PRDOBCC

i S9ER BEB PRDORRB

S b @

S @ @



' " cxgc° g ivy dcvv cv h' S lhxxc

G H

	CA/	EA/	CA/	EA/	C/
o	E:EE	F:RD	CF:NM	DE:FN	EP:NO

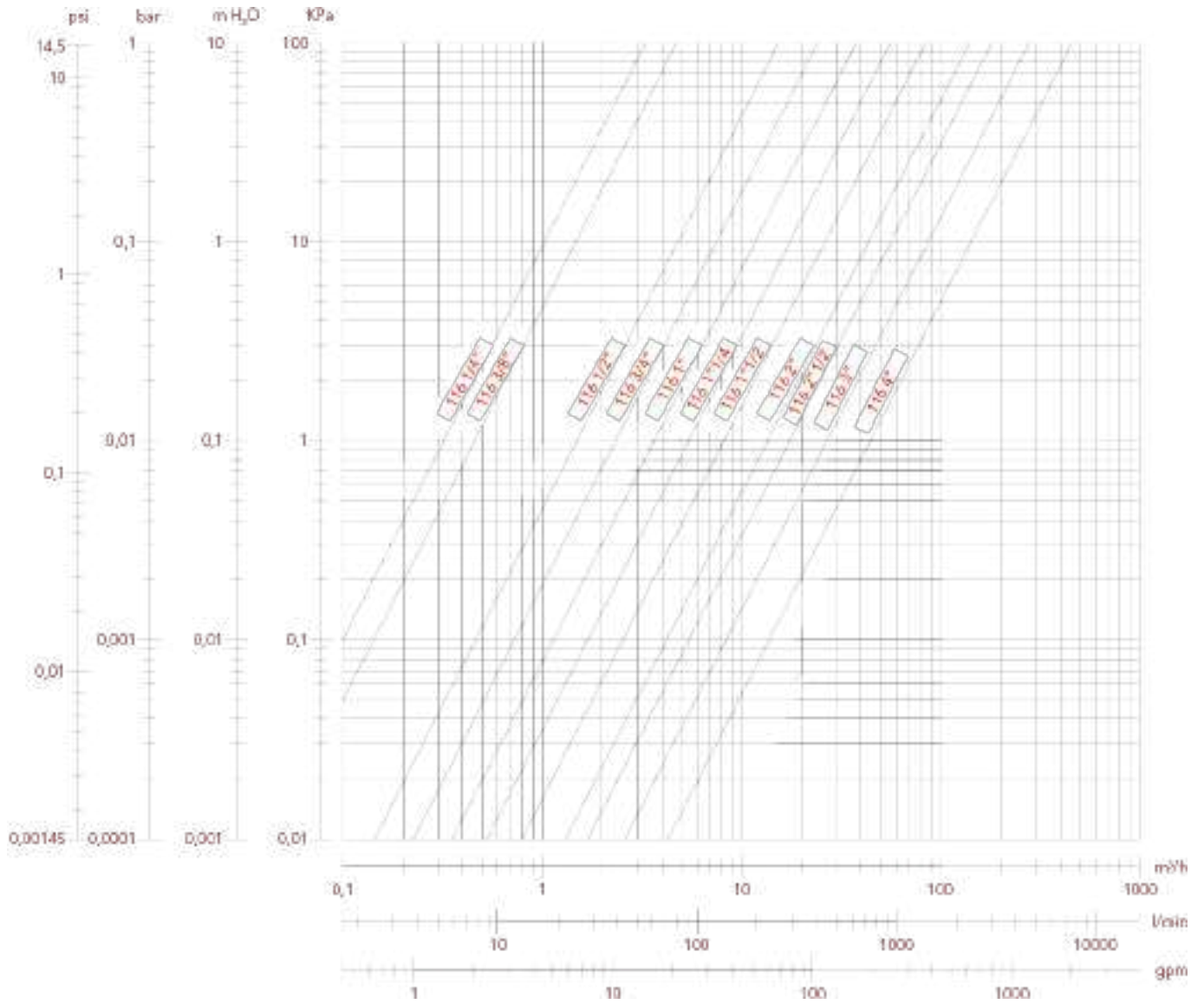



' " cxgc° g i vy dcvv cv h' S lhxxc

oi z

:

' : ; : @
lhxxc



I G1 :q	aA	VH	G'SV	SI WH U	I SG bS
TG1 :q	I HA	VH	G'SV	SI WH Ta	I SG bS
I S1 :q	I VA	TH	GTV	SI WH S	I VG SH
TG1 :q	SHA	TH	GTV	SI WH TU	aGVU
I 1 :q	SVA	TH	GTV	SI WH HH	aGVU
I 1 G1 :q	TSA	SV	GVSV	SI WH I U	UGS
I 1 S1 :q	UHA	SV	GVSV	SI WH I S	UGS
S1 :q	VHA	SV	GVSV	SI WSHH	SG a



i A A @
v 6 DCAD; E ; F 7 "
d ; @
w S, DB e: CMB e @
" SI' y DDP 6 glx hx l' y DDP d' hx l' y DDP 7 @



' " cxgc° g i vy dcvv cv h' S lhxxc

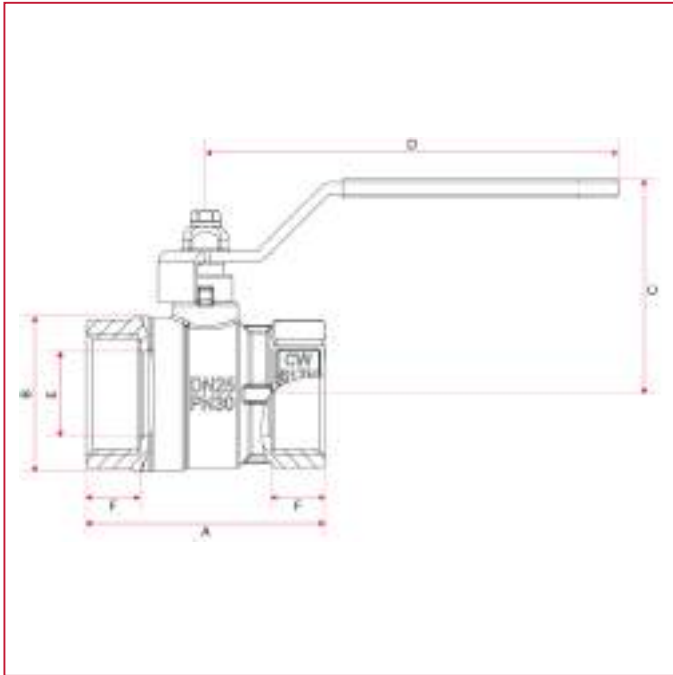

	i 3	r g 3	i 3	r 3	i 3	i 3 i 3	i 3 i 3	o 3
gx	P	CB	CM	DB	DM	ED	FB	MB
c	FF:F	FF:F	FP	ME	NN	ON	PP	CBE
d	DE:M	DF	DR	EN	FE	ME	NE	CR
e	FDE	FD:E	FF:P	MMP	MRE	CF:E	CR:E	RMP
g	PN	PN	PN	CCF	CCF	CEP:M	CEP:M	OMP
h	CB	CB	CF	CP:M	DE:M	EB	EO	FO
i	CB	CB	CD	CD	CM	ON	OP	CR
j	CB							
o A D	MB	MB	EB	EB	EB	DM	DM	DM
vd' ;	ODM	ODM	FEM	FEM	FEM	END:M	END:M	END:M



' " cxgc° g i vy dcvv cv h' S lhxxc

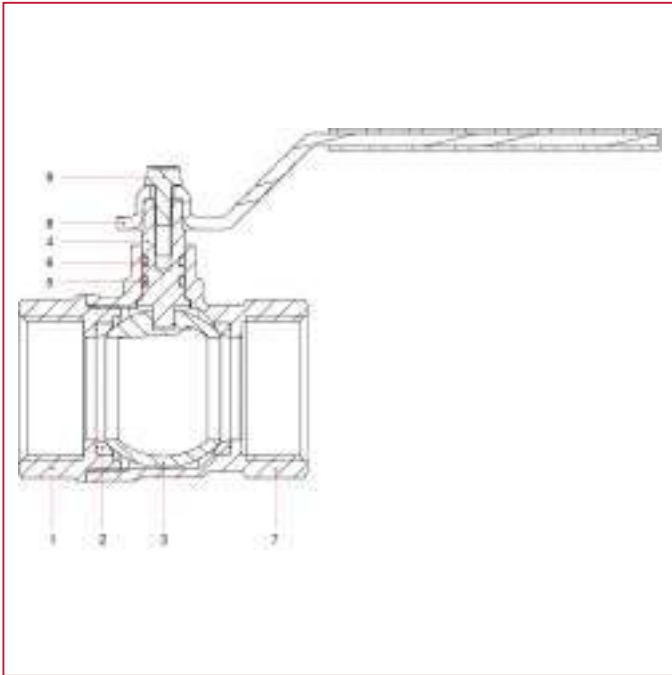

zy' @gh' e° lz" lyx	x@ wc" h° lcv
C i	C x ; e N00x
D '	D z@@@@
E d	C e ; e N00x
F '	C d e NCFx
M y;	C xd°
N y;	C
O d	C x ; e N00x
P i	C ; zBF
R '	C ; eFe



' "cxgc°givy dcvv cv h'S lhxxc

```

" ' @@@ ; : z"ih : : @ 7.
" 6 : : 6y;° 7.
    @
| ; : @
i : S
; : T
; : T @
; : 6 : @ @
; @ @
gl' c' ' hwdv
" S T
; S T
; T
; T
; T
; T
wclx" hxcxeh
: @
:
wclx ice" °h°
l" cz ' @@@
° CRDC; DMBNM
v @' 7.1
z S9ER BEB PRDOBCC
i S9ER BEB PRDCRRB
S b @
S @ @

```



' " cxgc° g i v y dcvv cv h' S lhxxc

G H

	CAE/	EAE/	CAE/	EAE/	C/	C/CAE/	C/CAE/	D/
o	E:EE	F:RD	CF:NM	DE:FN	EP:NO	M:BO	PN:NB	ON:M

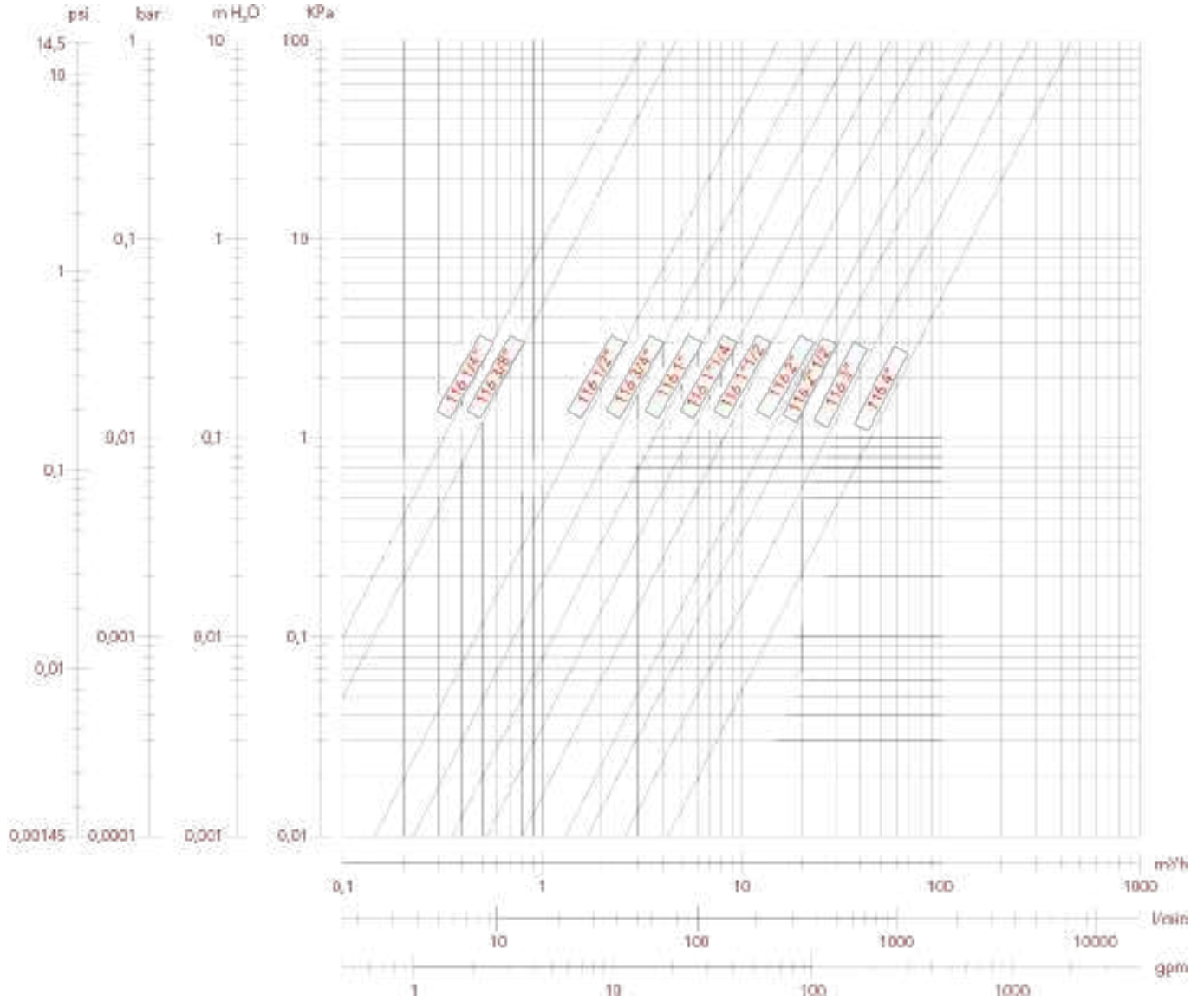



' " cxgc° g i vy dcvv cv h' S lhxxc

oi

' : ; : @
lhxxc



I G1 :q	aA	VH	G'SV	SI YHI U	I SG'WW
TG1 :q	I HA	VH	G'SV	SI YHTa	I SG'WW
I S1 :q	I VA	TH	G'TV	SI YHI S	I VG'SH
TG1 :q	SHA	TH	G'TV	SI YHTU	aG'W
I 1 :q	SVA	TH	G'TV	SI YH HH	aG'W
I 1 G1 :q	TSA	SV	G'V'SV	SI YH I U	UG'S
I 1 S1 :q	UHA	SV	G'V'SV	SI YH I S	UG'Sa
S1 :q	VHA	SV	G'V'SV	SI YHSH	SG'S



i A A @
v 6 DCAD; E ; F 7 "
d ; @
w S, DB e: CMB e @
" SI' y DDP 6 glx hx l' y DDP d' hx l' y DDP7@



' " cxgc° g i v y dcvv cv h' S lhxxc

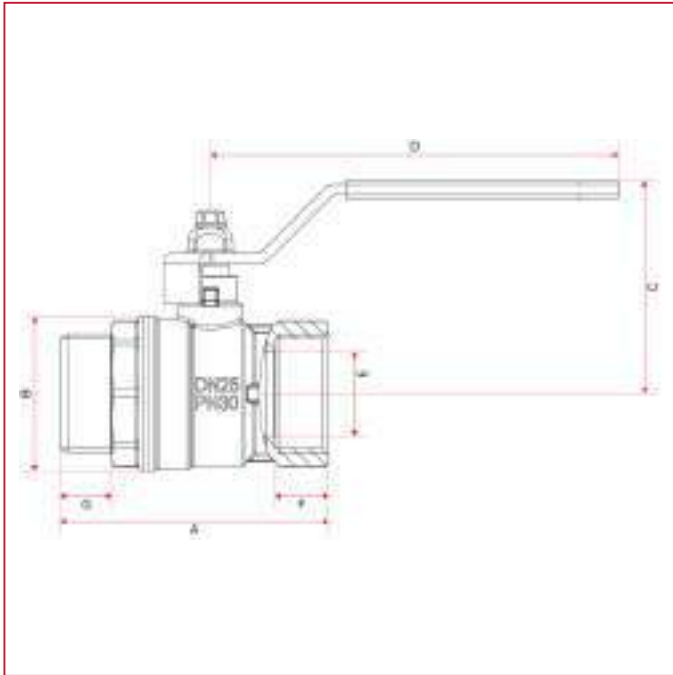

	i 3	r g 3	i 3	r 3	i 3	i 3 i 3	i 3 i 3	o 3
gx	P	CB	CM	DB	DM	ED	FB	MB
c	MF	MF	MP	ND:M	CM	PC:M	OCB:M	CCMM
d	DE:M	DF	DR	EN	FE	ME	NE	CR
e	FD	FD	FF	MM	MR	CF	CR	RM
g	PN	PN	PN	CCF	CCF	CEP:M	CEP:M	CMP:M
h	P	CB	CF	CP:M	DE:M	EB	EO	FO
i	CB	CB	CD	CD	CM	CN	CP	CR
j	CB:M	CB:M	CC:M	CD:M	CF:M	CO	CR	DC
o A D	MB	MB	EB	EB	EB	DM	DM	DM
vd' ;	ODM	ODM	FEM	FEM	FEM	END:M	END:M	END:M



' " cxgc° g i vy dcvv cv h' S lhxxc

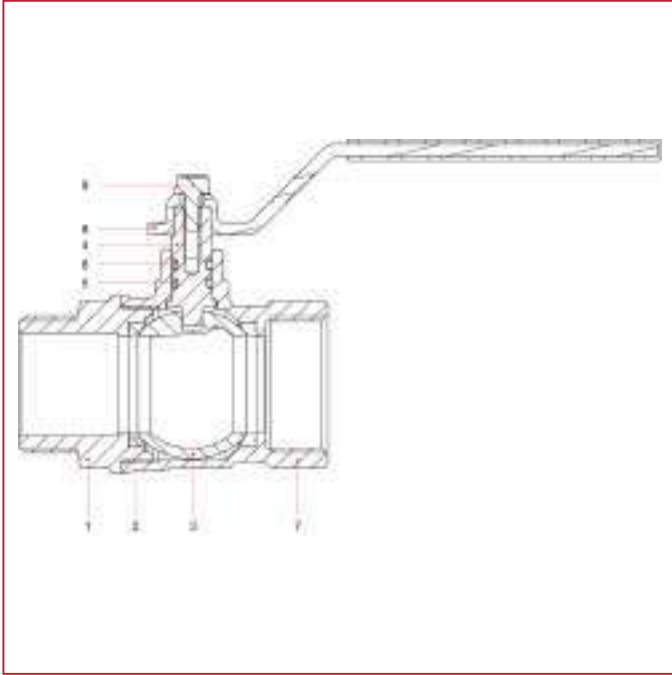

zy' @gh' e° lz" lyx	x@ wc" h° lcv
C w	C x ; e N00x
D '	D z@@@@
E d	C e ; e N00x
F '	C d e NCFx
M y;	C xd°
N y;	C
O d	C x ; e N00x
P i	C ; zBF
R '	C ; eFe



' "cxgc°g i vy dcvv cv h' S lhxxc

" ' @@@ ; : z"ih : : @ 7.

" 6 : : @

| ; : @

i : T S

; ; ; ; T @

; ; ; ; @ 7 @ @

; ; ; ; @ @

gl' c' ' hwdv ; ; ; ; S T

" ; ; ; ; T T

; ; ; ; T

wclx" hxcxeh ; ; ; ; T

;

wcx ice" °h° @

l" cz ' @@@

° CRDC; DMBNM

v @' 7.1

z S9ER BEB PRDOBCC

i S9ER BEB PRDCRRB

S b @

S @ @



' " cxgc° g i v y dcvv cv h' S lhxxc

G H

	CAE/	EAE/	CAE/	EAE/	C/	C/CAE/	C/CAE/	D/
o	E:EE	F:RD	CF:NM	DE:FN	EP:NO	M:BO	PN:NB	CN:M

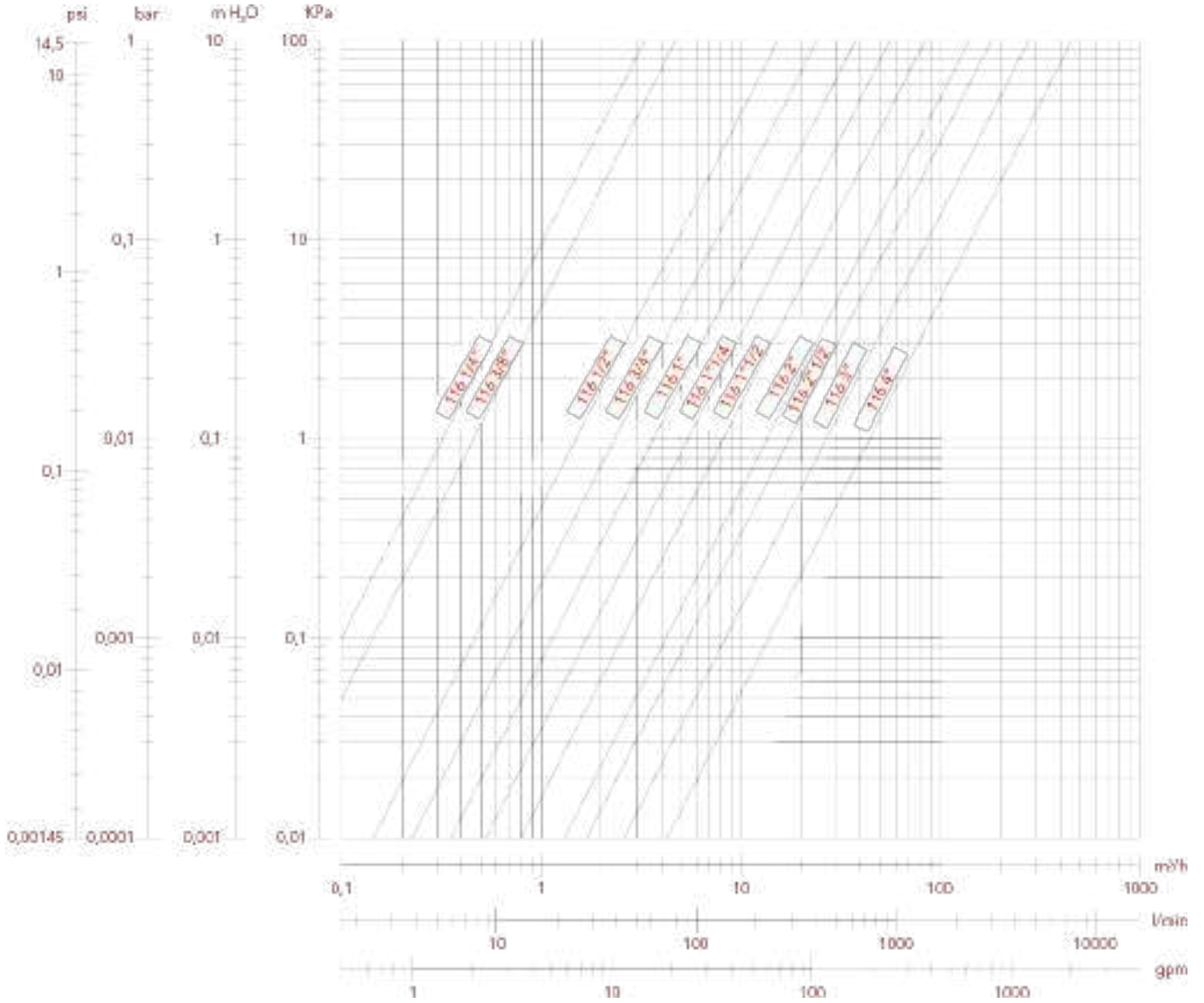



' " cxgc° g i vy dcvv cv h' S lhxxc

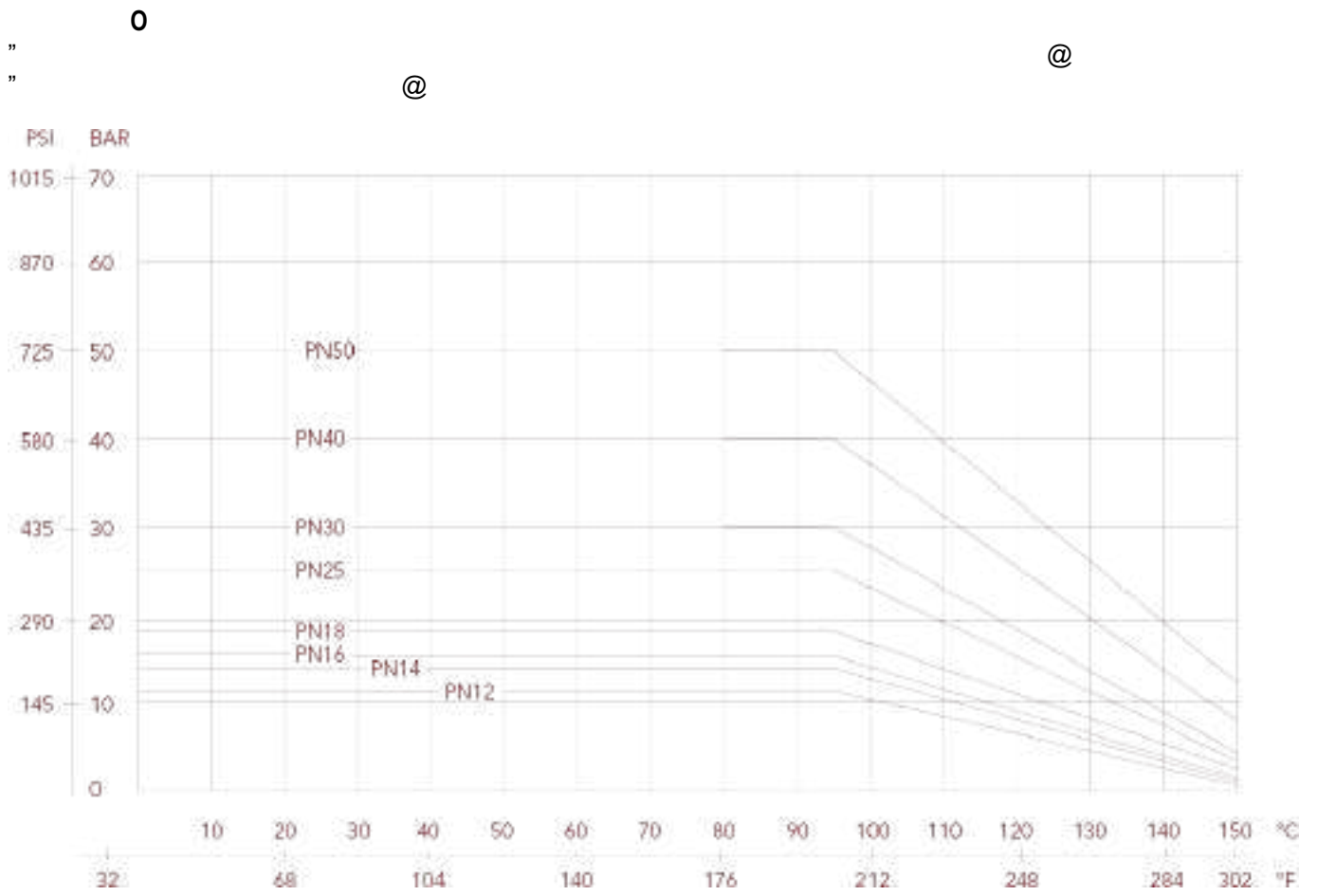



ITAP S.p.A.
Via Ruca 19
25065 Lumezzane
Brescia (ITALY)
Tel 030 8927011
Fax 030 8921990
www.itap.it - info@itap.it

F D
FSHSI HSI a