

2/2-Way Pilot Operated, Diaphragm Type, Solenoid Valves.

DATA SHEET
9130 D

For steam and hot water application upto 5 bar pressure
Normally Closed, Energised To Open.

SPECIFICATIONS

Sizes	: 10mm (3/8") to 50mm (2").
End Connections	: Standard-G-ISO-228 (BSP-F).
Construction-Body	: Upto 20mm (3/4") Brass forged IS 6912 and above in SS ASTM A351 Gr.CF8 or CF8M.
Diaphragm-Seat	: Standard Silicon.
Differential Pressure	: From 0.5 to 5 bar (See Table).
Coil Voltage	: Standard-230-volts, 50Hz. A C. Optional - 24,110, 240 V AC 50Hz or 60Hz & 24 V DC.
Coil Insulation and Temperature.	: Ambient upto 42°C. Class 'C' insulated upto 180°C.
Coil Rating	: Continuously rated.
Enclosure	: Standard-General purpose : SQ. moulded coil upto IP-20, Optional-Weatherproof SQ. moulded coil upto IP-67, Flameproof coil upto FLP IIC.
Approvals	: CIMFR Dhanbad, CCOE
Fluids	: Steam temp. upto 120°C. Hot water temp upto 95°C.
Sales Point	: Diaphragm Pilot operated, standard valve for low pressure steam application.
Application	: Steaming equipment, textile , processing equipment, laundry equipment, kitchen equipment and others.



Note : Not suitable for back pressure from outlet side. Hot water temperature limited upto 95°C only. Suitable for wet steam: For high pressure steam, use valve type 9130H. For instruction manual refer Gen IM SV & Gen IM Coils. Manual override not available. **USE OF FILTER IN THE INLET SIDE IS HIGHLY RECOMMENDED.**

SPECIFICATION TABLE 2/2 WAY NORMALLY CLOSED

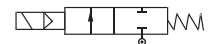

Catalogue Number	Pipe Size	Orifice Size	Flow Factor Kv	Minimum Pressure	Maximum Operating Pressure (bar)		BTP	Material		Constr. Ref.	VA Rating	Coil Type	Housing
	Inch	mm	M ³ /hr.	bar	Hot Water*	Steam		bar	Body		Seat		
9130D104	3/8	16	2.6	0.5	5	4	40	BR	Silicon	159	36	M50-HT	SQ
9130D154	1/2	16	3.6	0.5	5	4	40	BR	Silicon	159	36	M50-HT	SQ
9130D204	3/4	20	5.3	0.5	5	4	40	BR	Silicon	159	36	M50-HT	SQ
9130D254	1	25	8.6	0.5	5	4	40	CF8	Silicon	159	36	M50-HT	SQ
9130D304	1 1/4	28	14.0	0.5	5	4	40	CF8	Silicon	159	36	M50-HT	SQ
9130D354	1 1/2	34	17.3	0.5	5	4	40	CF8	Silicon	159	36	M50-HT	SQ
9130D504	2	45	30.5	0.5	5	4	40	CF8	Silicon	159	36	M50-HT	SQ

* Hot water at 95°C only

ELECTRICAL REFERENCE

Coil Type	Power Consumption & Watt Rating		Class of Insulation	Protection
	AC			
	VA Inrush	VA Holding		
M 50 HT SQ	50	36	C	GP/WP IP-67
M 50 HT RD	50	36	C	GP/WP IP-67
M 50 HT FLP IIC	50	36	C	IS/IEC 60079-1:2007, Group IIC, IS 12063-1987 IP-67 (IEC 60529:1989).

DIMENSIONS (IN MM)							
Catalogue Number	Pipe Size	Constr. Ref.	A	B	C	D	Weight (Approx.)
	Inch						Kgs. ⬠
9130D104	3/8	159	65	28	129	54	1.110
9130D154	1/2	159	65	28	129	54	1.110
9130D204	3/4	159	80	32	134	66	1.555
9130D254	1	159	95	41	139	77	2.090
9130D304	1 1/4	159	100	43	144	82	2.435
9130D354	1 1/2	159	118	43	144	97	2.575
9130D504	2	159	137	58	151	117	3.655

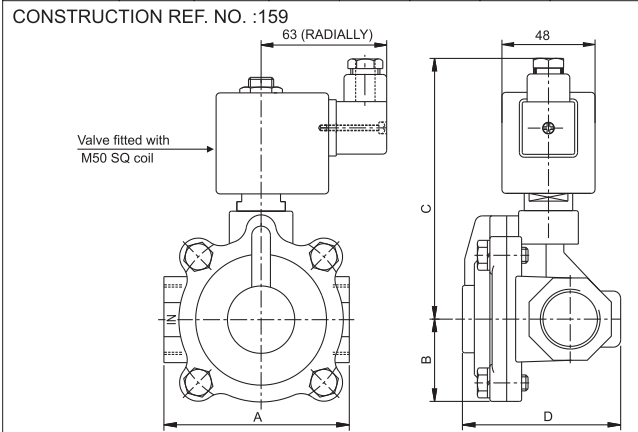

⬠ Weight with SQ enclosure only, ask AVCON for other weights.

Valve fitted with M50 RD GP coil -
General purpose enclosure as per IP-20

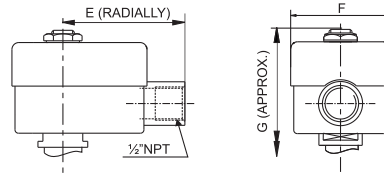

Valve fitted with M50 RD WP coil -
Waterproof metallic enclosure as per IS12063-1987 IP-67.

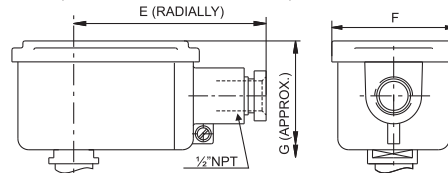

Valve fitted with M50 FLP IIC coil -
Flameproof metallic enclosure as per IS/IEC-60079-1:2007.

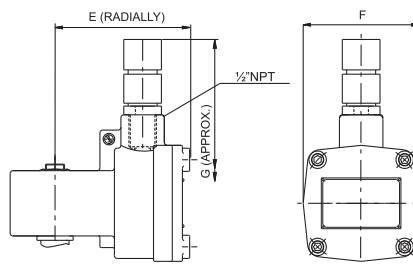

Catalogue Number	Pipe Size Inch	Constr. Ref.	E (RADIALLY)			F			G (APPROX.)		
			RD GP	RD WP	FLP	RD GP	RD WP	FLP	SQ WP	RD WP	FLP
9130D104	3/8	159	66	96	96	57	68	80	120	125	190
9130D154	1/2	159	66	96	96	57	68	80	120	125	190
9130D204	3/4	159	66	96	96	57	68	80	125	130	195
9130D254	1	159	66	96	96	57	68	80	130	135	200
9130D304	1 1/4	159	66	96	96	57	68	80	135	140	205
9130D354	1 1/2	159	66	96	96	57	68	80	135	140	205
9130D504	2	159	66	96	96	57	68	80	142	147	212

TEMPERATURE TABLE FOR SATURATED STEAM UNDER GAUGE PRESSURE

Pressure (bar)	Temp (°C)	Pressure (bar)	Temp (°C)
0.5	111	6	165
1	120	7	170
1.5	127	8	175
2	134	9	180
2.5	139	10	184
3	144	11	188
3.5	148	12	191
4	152	13	195
4.5	155	14	198
5	159	15	200

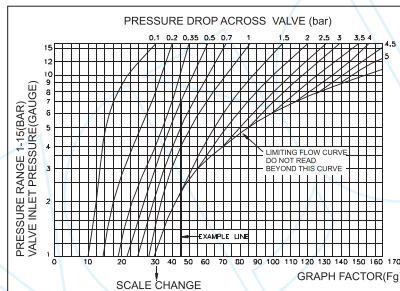
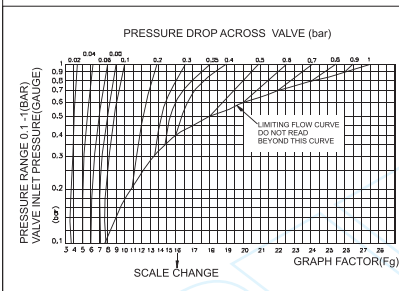

FLOW CALCULATION GRAPHS FOR SATURATED STEAM: The valve flow coefficient $K_v=1$, If one cubic meter (m^3) water (at $30^\circ C$) is passing through the valve per hour with a pressure drop (Δp) of 1 bar. To select the right valve with certain K_v value, read the steam flow graphs as follows.

EXAMPLE: A valve is required to pass 400 Kg/h (Q_m) of saturated steam at inlet pressure of 7 bar (g) (Δp) of 0.5 bar: What is the K_v ?

SOLUTION: Read the steam graph to find the graph factor(F_g) and use the formula : $K_v = \frac{Q_m}{F_g} = \frac{400}{45} = 8.5$

NOTE : Absolute pressure = gauge pressure plus atmospheric pressure of 1.033 bar. In most system it is desirable to keep the pressure drop to a minimum. Never use a (Δp) greater than 50% of the absolute inlet pressure because excessive pressure drop cause irregular flow.

Note:

Technical specifications, details & dimensions are subject to change without prior notice. Dimensions in the table are approximate subject to final confirmation by AVCON.